

SmartScope® E45

SmartScope E45 is a floor model 3-axis video measurement system featuring a large travel fixed bridge design. The fixed lens IntelliCentric™ E optical system and digital zoom provide a high resolution image engineered for video edge detection metrology. SmartScope E45 also offers:

- **Advanced Lighting** – All LED coaxial, substage profile, and SmartRing™ light illumination comes standard
- **Sturdy, Stable Construction** – Parts move on a precision DC motor-driven Y-axis stage while the optics travel in the X-axis mounted on a rigid bridge support structure for metrological integrity.
- **Multisensor Versatility** – Optional touch probe.

Large Capacity Video Measurement System



Shown with optional Touch Probe.



SmartScope® E45

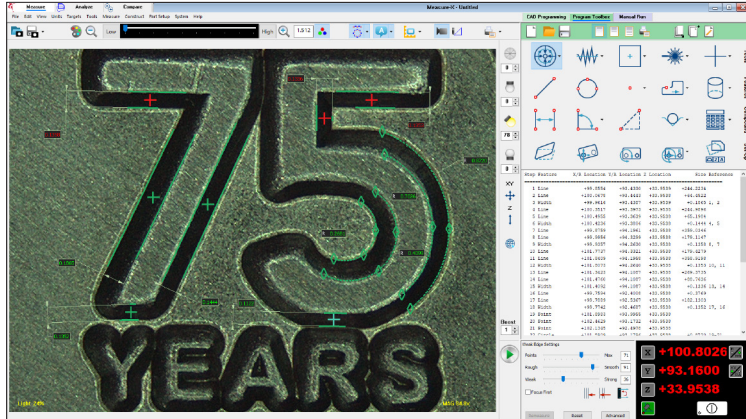

Full feature Measure-X® metrology software offers 2D CAD program generation and general-purpose dimensional measurement with multisensor and rotary axis support.

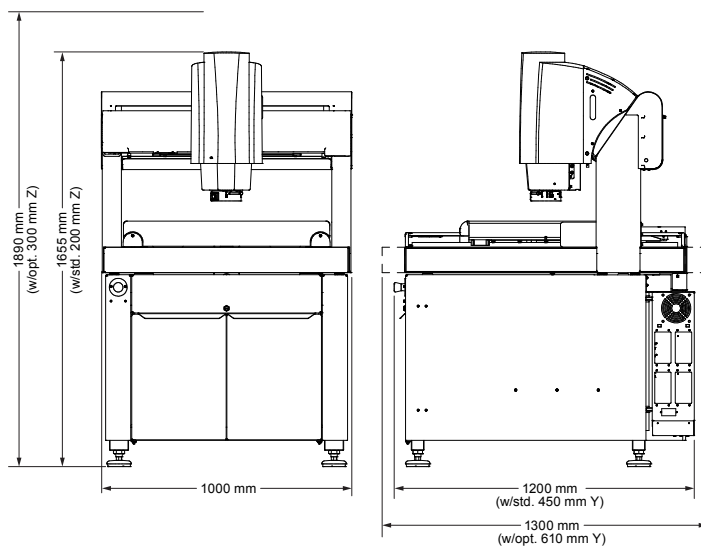

System Weight: 960 kg
Shipping Weight: 1020 kg

	Standard	Optional
XYZ Travel	500 x 450 x 200 mm	Extended Y axis, 610 mm; extended Z axis, 300 mm
XYZ Scale Resolution	0.1 µm	
Drive System	DC servo with 3-axis control (X, Y, Z); with 3-axis joystick controller	Multifunction handheld controller (in lieu of joystick)
Worktable	Nickel plated steel, with fixture holes, removable stage glass, 65 kg recommended max payload	
Rotary Axis		Miniature Servo Rotary (MSR™)
Optics*	Fixed optical magnification with digital zoom, E 8.10 standard lens	Replacement Lenses: E 16.20 Wide Field-of-View/Long Working Distance, E 4.5 High Magnification
Illumination	Substage LED profile, coaxial LED surface, SmartRing LED ring light	Conical SmartRing (included with E 4.5 lens)
Metrology Camera	6 megapixel color digital metrology camera	
Field of View	7.0 mm x 5.1 mm to 1.7 mm x 1.3 mm	E 16.20: 14.0 mm x 10.4 mm to 3.4 mm x 2.6 mm E 4.5: 3.5 mm x 2.6 mm to 0.85 mm x 0.65 mm
Resolution**	10 µm	E 16.20: 20 µm E 4.5: 5 µm
Working Distance	62 mm	E 16.20: 110 mm E 4.5: 31 mm
Sensor Options		Tactile: TP20 or TP200 Touch Probe
Software	Measure-X Measure and Compare	Productivity software: Measure-X Analyze, EVOLVE® Suite (Design, Manufacturing, SmartProfile®, SPC) Offline software: Measure-X
System Controller	Windows® based, with up-to-date processor and onboard networking/communication ports	
Controller Options		24" flat panel LCD monitor, or dual 24" flat panel LCD monitors, keyboard, 3-button mouse (or user supplied)
Power Requirements	100-120 VAC or 200-240 VAC, 50/60 Hz, 1 phase, 700 W	
Safe Operating Environment	15-30 °C, non-condensing	
Rated Environment	Temperature 18-22 °C, stable to ± 1 °C, max rate of change 1 °C / hour, max vertical gradient of 1 °C / meter; 30-80% humidity; vibration <0.001g below 15 Hz	
XY Area Accuracy	$E_2 = (2.8 + 5L/1000)$	
Z Linear Accuracy	$E_1 = (3.8 + 5L/1000) \mu\text{m}$	$E_1 = (2.8 + 5L/1000) \mu\text{m}$ (requires optional E 4.5 lens)

Accuracy is evaluated with a QVI verification procedure where "L" is measured length in millimeters. Specifications apply within the rated environment. Standard optical specifications apply at the maximum digital magnification of the standard configuration. XY Accuracy applies with an evenly distributed load up to 10 kg in the standard measuring plane. The standard measuring plane is defined as a plane that is within 25 mm of the worktable surface. Depending on load distribution, accuracy at maximum payload may be less than standard. This equipment complies with EMC directive EN IEC 61326-1, Class A.

*Lenses can be manually interchanged to change magnification and working distance.

**Based on width measurement of USAF resolution test chart in best focus at the maximum digital magnification.



Confidence. When Results Matter.™

World Headquarters: Rochester, NY, USA • 585.544.0400 • www.ogpnet.com

OGP Shanghai Co, Ltd: Shanghai, China

86.21.5045.8383/8989 • www.smartscope.com.cn

OGP Messtechnik GmbH: Hofheim-Wallau, Germany

49.6122.9968.0 • www.ogpmesstechnik.de

Optical Gaging (S) Pte Ltd: Singapore • 65.6741.8880 • www.smartscope.com.sg

© 2024 Quality Vision International Inc. Specifications subject to change without notice. All rights reserved. Trademarks are the properties of their respective owners.

Export of this product is controlled under U.S. Export Regulations. An Export License may be required for deliveries or re-export outside the United States. Part Number 791078-0124